



# Aton<sup>®</sup> Connect<sup>™</sup> Host Integration Toolkit Data Sheet



**I**f you are like most developers and engineers, you want a tool that is easy to learn, gets the job done quickly, and is supported by knowledgeable staff who are available when you need them. Our team of software developers took your desires seriously to create one of the best products we have ever developed!

**Aton Connect Host Integration Toolkit** is designed to help you access enterprise data residing on mainframes and deliver it to your web site or portal quickly and effectively using the Microsoft tools and programming languages you already know.

Now, you can give your business line managers what they are demanding without having to purchase expensive middleware or wait for time consuming mainframe programming to be completed.

Use **ASP.NET** to build a custom solution for your enterprise needs. Give your line staff the ability to close more sales, make better decisions and reduce costs by having the right data wherever they are. Let your custom application sort data using business rules to free staff for more important activities.

## Why Mainframes Are Still Around

As much as 70 percent of corporate data still lives on mainframes. In fact, the IBM zSeries is having a sales revival. These powerhouse machines run mission critical applications in a wide variety of industries, in education and in government with remarkably high performance, reliability and security. They represent a huge investment in staff, applications and equipment which enterprises rely on for daily operations.

Unlike newer client/server and Internet based systems, the huge installed base of mainframe programming is very difficult and expensive to modify. Replacement with newer systems and applications may not be economically feasible for a company with millions of dollars invested in them, not to mention the looming risk of moving mission critical business processes off of these reliable systems.

Yet, businesses, universities and colleges and government organizations that utilize mainframes must find better ways to easily tap into the wealth of data stored in them to meet new business requirements and changing customer expectations.

**Aton International, Inc.**  
11490 Old Ranch Road  
Los Altos Hills, CA 94024  
USA

Toll Free: 800-833-0835  
Phone: +1 650-938-9328  
Fax: +1 650-938-9368  
E-mail: sales@aton.com

## Aton® Connect™ Host Integration Toolkit Helps Bridge Gap Between Mainframe and User

The Aton Connect server-side software component in the Toolkit can easily be used to provide crucial data in the most suitable format for the user and display it in a custom web page. The component uses a TCP/IP connection to link to a private or public TN3270 server to provide access to mainframe data for presentation in the web browser.

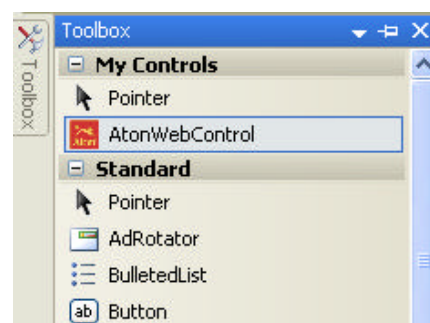

Using TN3270 terminal emulation, the Aton Connect software component allows the developer using Visual Studio 2005 to provide quick access to key data via any web browser – for desktops, laptops and mobile devices. Because the Aton Connect component is highly reliable and quick to use, IT departments and integrators can produce results very rapidly to gain substantial return on investment.

### Aton® Connect™ Host Integration Toolkit At A Glance:

#### Product Features:

Uses standard TCP/IP for communication

Simple control interface

Total control of virtual screen, keyboard and error messages by application program (ASPX page),

No pop-up message boxes from the ASP.NET control; all communication is through event occurrences.

Host session can be active in the background while IIS is serving the web browser session.

Component is available as an ASP.NET control, callable by Visual C# or Visual Basic .NET

Supports ASP .NET asynchronous tasks as a class object to allow greater scalability for your application

#### Benefits to User:

Easy to use. No proprietary protocols to learn.

Rapid implementation of your ASP .NET design

Unlimited design possibilities.

Ideal for server based applications.

Reduces delays in serving the data to your user.

Work with the language you know best.

Number of simultaneous transactions can scale with your needs.

### What Can You Do With Aton® Connect™ Host Integration Toolkit ?

Make corporate data easier to view and more accessible, streamline business processes, or have the server do preliminary sorting to save employee time. Here's a sample from the Toolkit showing the library catalog accessed via public server from the University of Florida.

## From 1980's "Green Screen" From The Mainframe

```

Search Request: k=golf                                     Keyword Index
Search Results: 330 Entries                               UNIV - CENTRAL FLORIDA
-----
DATE TITLE                                               AUTHOR
15 2004 The battle for Augusta National : Hootie,       Shipnuck, Alan,      CF
16 2004 Dr. Divot's guide to golf injuries : a han     Foster, Larry,       CF
17 2004 Expressive politics : issue strategies of      Boatright, Robert G. CF
18 2004 Fit for golf a personalized conditioning r     Kuzmic, Boris.      CF
19 2004 The golfers : the story behind the paintin   Lewis, Peter N.     CF
20 2004 Golf and the game of leadership an 18-hole    McHugh, Donald E.   CF
21 2004 The golfer's stroke-saver workout : thirty    Skinner, Alton.     CF
22 2004 Golf and the game of leadership : an 18-ho    McHugh, Donald E.   CF
23 2004 Golfonomics /                                  Shmanske, Stephen, CF
24 2004 Golf fundamentals /
25 2004 I call the shots straight talk about the g    Miller, Johnny,     CF
26 2004 In search of Burningbush a story of golf,     Konik, Michael.     CF
27 2004 Managing wetlands on golf courses /          Libby, Gary R.      CF
28 2004 National identity and the conflict at Oka     Kalant, Amelia,     CF
-----
CONTINUED ON NEXT SCREEN ---
START Restart F Forward B Back R Review Search
HIST See Searches H Help MENU Databases SET Set values
MARK Mark results EMAIL Mail results E Introduction 0 Other Ccmds

NEXT COMMAND:
IBM-3278-2 L= (3538) R= 128.227.128.75(29)

```

## To Practical User Interface With Clickable Links & Buttons

Search Result List - From Library: UNIV - CENTRAL FLORIDA

Search Results: 330 Item(s)

Search Request: Keyword(s) Anywhere = golf

Item #	Date	Title	Author	Loc
<a href="#">15</a>	2004	The battle for Augusta National : Hootie,	Shipnuck, Alan,	CF
<a href="#">16</a>	2004	Dr. Divot's guide to golf injuries : a han	Foster, Larry,	CF
<a href="#">17</a>	2004	Expressive politics : issue strategies of	Boatright, Robert G.	CF
<a href="#">18</a>	2004	Fit for golf a personalized conditioning r	Kuzmic, Boris.	CF
<a href="#">19</a>	2004	The golfers : the story behind the paintin	Lewis, Peter N.	CF
<a href="#">20</a>	2004	Golf and the game of leadership an 18-hole	McHugh, Donald E.	CF
<a href="#">21</a>	2004	The golfer's stroke-saver workout : thirty	Skinner, Alton.	CF
<a href="#">22</a>	2004	Golf and the game of leadership : an 18-ho	McHugh, Donald E.	CF
<a href="#">23</a>	2004	Golfonomics /	Shmanske, Stephen,	CF
<a href="#">24</a>	2004	Golf fundamentals /		CF
<a href="#">25</a>	2004	I call the shots straight talk about the g	Miller, Johnny,	CF
<a href="#">26</a>	2004	In search of Burningbush a story of golf,	Konik, Michael.	CF
<a href="#">27</a>	2004	Managing wetlands on golf courses /	Libby, Gary R.	CF
<a href="#">28</a>	2004	National identity and the conflict at Oka	Kalant, Amelia,	CF

Click on Item # above to view item details.

## How Aton® Connect™ Host Integration Toolkit Works:

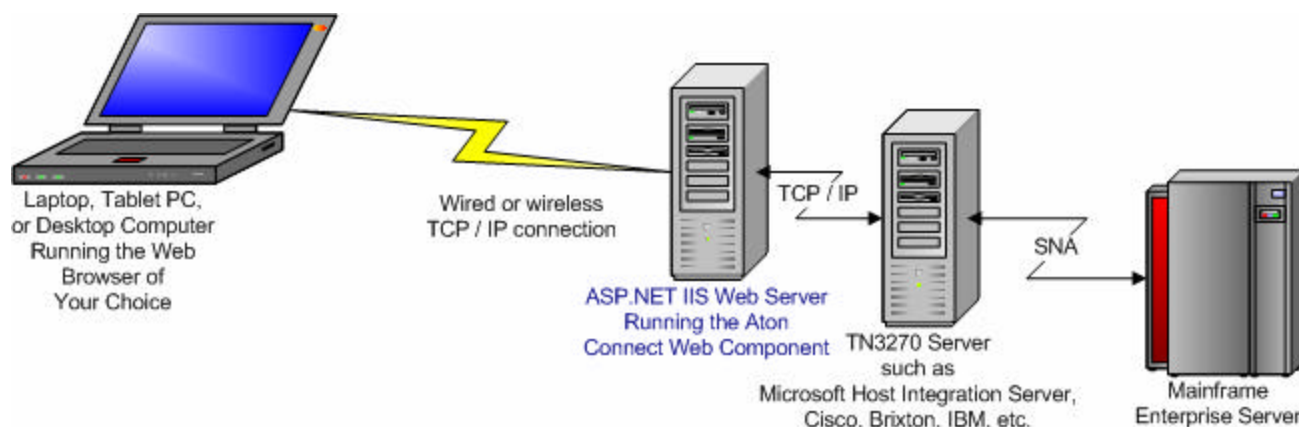

The Aton Connect web component enables you to obtain host access directly from a web application using the Telnet TN3270 client protocol for all versions of Microsoft Windows Vista, XP, Windows 2003 Server and Windows 2000 with SP4. It provides access to applications running on IBM zSeries, 390 and 30XX type mainframe enterprise servers.

The current version of our product does not directly support SSL or SSH for the communication from IIS to the mainframe. Security between the server containing IIS with the Aton TN3270 control and the mainframe is normally provided in the internal LAN or via VPN for external connections to the mainframe. Aton Connect Host Integration Toolkit is compatible with Stunnel open source SSL (see <http://www.stunnel.org>.) A new version of Aton Connect which includes SSL is currently in development.

Aton Connect Host Integration Toolkit also supports the asynchronous web page rendering feature added to ASP .NET 2.0. Instead of using the Aton Web Control, the designer can create an ASP .NET 2.0 asynchronous task that interacts with the Aton Host Class. The use of the ASP .NET 2.0 asynchronous web page rendering feature can improve the scalability of the design by releasing IIS service threads for other activity while waiting for mainframe responses.

Most enterprises already have TN3270 servers in operation for desktop access. The TN3270 server is usually available in mainframe environments as an interface between TCP/IP clients and IBM SNA host networks. TN3270 servers are provided by various sources including Cisco, Brixton, IBM, Microsoft and others. The TN3270 server software may reside in the mainframe as an application, or in a separate support server.

The IBM 3270 family of interactive terminal products includes many types of video terminals, cluster controllers and printers. The specific IBM terminal that this component emulates is the IBM 3278 Model 2. The .NET Framework 2.0 or later must also be installed to use the Aton Connect Host Integration Toolkit.

## What's Inside:

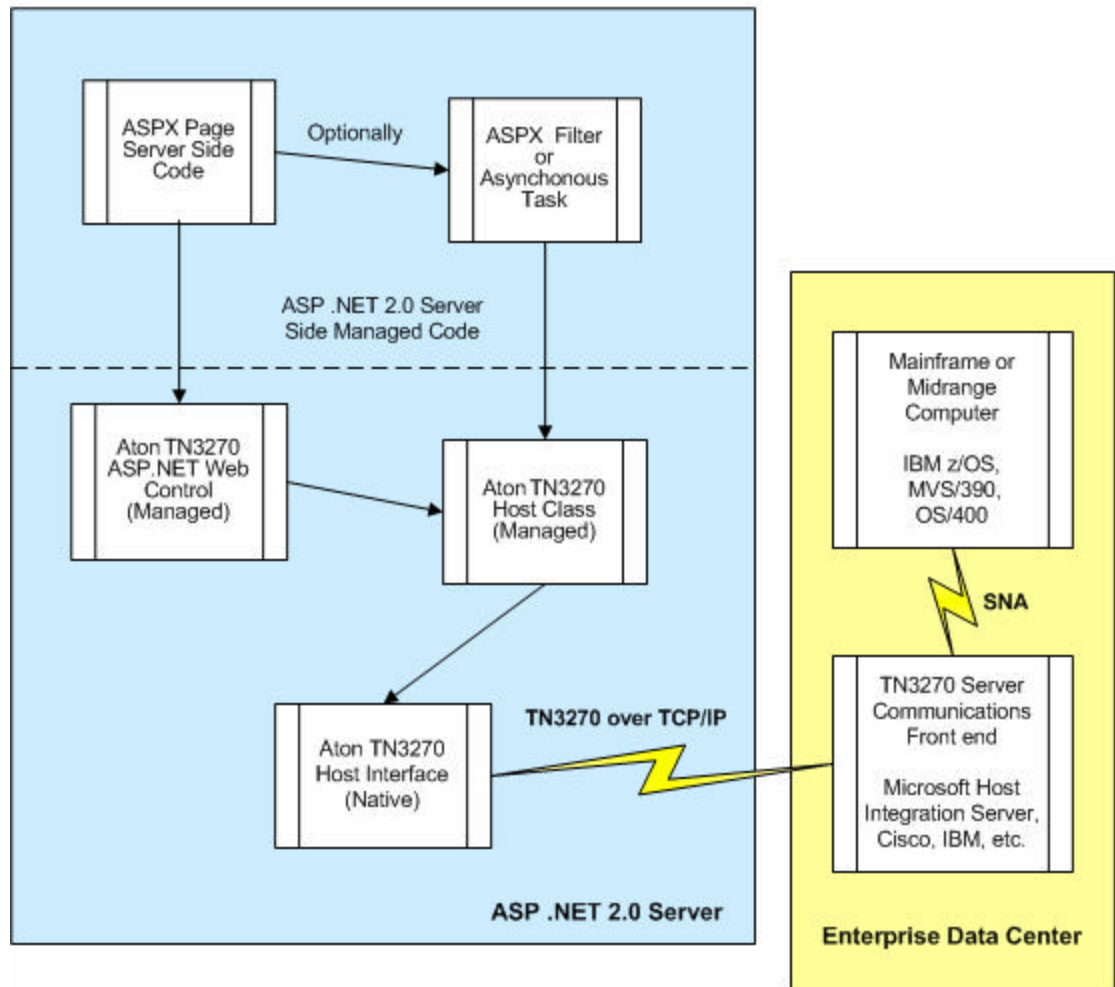

## What's Inside

The Aton Connect Web Control component is installed on an ASPX web page which is viewed through the Internet browser. The web component works through the Windows operating system to communicate via TCP/IP to the TN3270 server which, in turn, communicates via SNA to the mainframe.

Your custom web application is an ASPX page you create in Visual Studio 2005. This ASPX page exists in a subfolder containing several files. This subfolder is then added to your web site, and other portions of the web site link to the .aspx file in the subfolder. The subfolder itself contains a subfolder named BIN that contains several DLL files.

The ASPX page may display the data exactly as received from the mainframe. But, more commonly, the code in the ASPX page will interact with one or more mainframe application screens and then copy or "screen scrape" data of interest to internal variables. The reformatted data is presented to the user in a friendly graphical manner using all of the formatting power of the web browser and ASP .NET 2.0.

Aton Connect Host Integration Toolkit also supports the asynchronous web page rendering feature added to ASP .NET 2.0. Instead of using the Aton Web Control, the designer can create an

ASP .NET 2.0 asynchronous task that interacts with the Aton Host Class. The use of the ASP .NET 2.0 asynchronous web page rendering feature can improve the scalability of the design by releasing IIS service threads for other activity while waiting for mainframe responses.

The samples contained in the Toolkit were built to demonstrate the power and ease of use of the Aton Connect web control for accessing information located on enterprise mainframe servers. You are free to use the sample code as a base for building web applications that meet your company's business process or customer service needs.

For the Aton Toolkit samples, the data being accessed is either from the United States Library of Congress database or from the library catalog for the University of Florida. Both of these organizations currently provide open public access servers allowing you to test our components and samples without accessing proprietary corporate data.

## **Everything You Need for a Successful Project**

Aton Connect Host Integration Toolkit includes copies of Aton Connect Web Control and Aton Connect Host Class software components; documentation and royalty-free sample code (three C# and five VB.NET samples) for incorporating the Aton Web Control and Aton Host Class components into your custom application; one (1) year of support for a single developer via e-mail and phone for issues directly related to integrating our product into your custom application; and one (1) year of product updates.

The source code for the samples is included as a digital file in the Aton Connect Host Integration Toolkit. A tutorial describing the samples is provided in the documentation. Additional samples that interact with the Aton Host Class are also included.

You can get started on your project right away. A free 90 day trial is available so you can try before you buy.

## **What Kind of License Does Aton's Toolkit Have?**

The Toolkit is licensed on a subscription basis annually per individual developer. There are no additional runtime or session fees.

There is no limit on the number of Aton components with modified sample code you may install on servers on your premises for your company's use.

You may modify the Sample Code (identified in the "Samples" directory) and use the Sample Code, as modified, in conjunction with the Aton Software Component on one or more servers located at your premises.

## **What About Use Limitations?**

You may not transfer, rent, lease, lend, provide commercial hosting services to third parties using the Software Component or sample code or sublicense the Toolkit, without prior written approval of Aton International, Inc. and payment of additional licensing fees.

If you are developing an application or device for resale to one or more customers, you need to purchase a redistribution license to include any of our software from the Toolkit in your product.

If you need to run any software from the Toolkit on servers not located on your company's premises or not owned by your company, please contact us.

This is only a very brief overview of our license agreement. Please read and understand the complete license agreement before beginning any development using the Aton Connect Host Integration Toolkit.

## What Developers Testing Aton® Connect™ Host Integration Toolkit Said:

*“Your product saved us many hours and will definitely be recommended for future mainframe/3270 projects.”*

*“So far so good, I was able to easily mirror the old VB code for connect and logon . . .”*

## Pricing Information



**Special Introductory Offer:** \$2400 for one developer for 12 months. Discounts for multiple developers.

### The Toolkit includes:

- (1) Copies of Aton Connect Host Integration Toolkit software components,
- (2) Documentation and sample code (3 C# and 5 VB.NET samples) for incorporating the Aton Web Control and Aton Host Class components into your custom application.
- (3) 1 year of support for a single developer via e-mail and phone for issues directly related to integrating our product into your custom application.
- (4) 1 year of product updates.
- (5) This is a subscription license. Annual renewal is \$800 for one developer. Discounts available for multiple developers.

**Free 90 day trial available. Please contact us to receive your copy.**

**Toll Free:** 1-800-833-0835 US and Canada  
**International:** +1-650-938-9328 (GMT- 8 )  
**Fax:** +1-650-938-9368

**Email:** sales@aton.com  
**Web site:** http://www.aton.com  
**Postal Address:** Aton International, Inc.  
 11490 Old Ranch Road  
 Los Altos Hills, CA 94024-6312  
 USA